

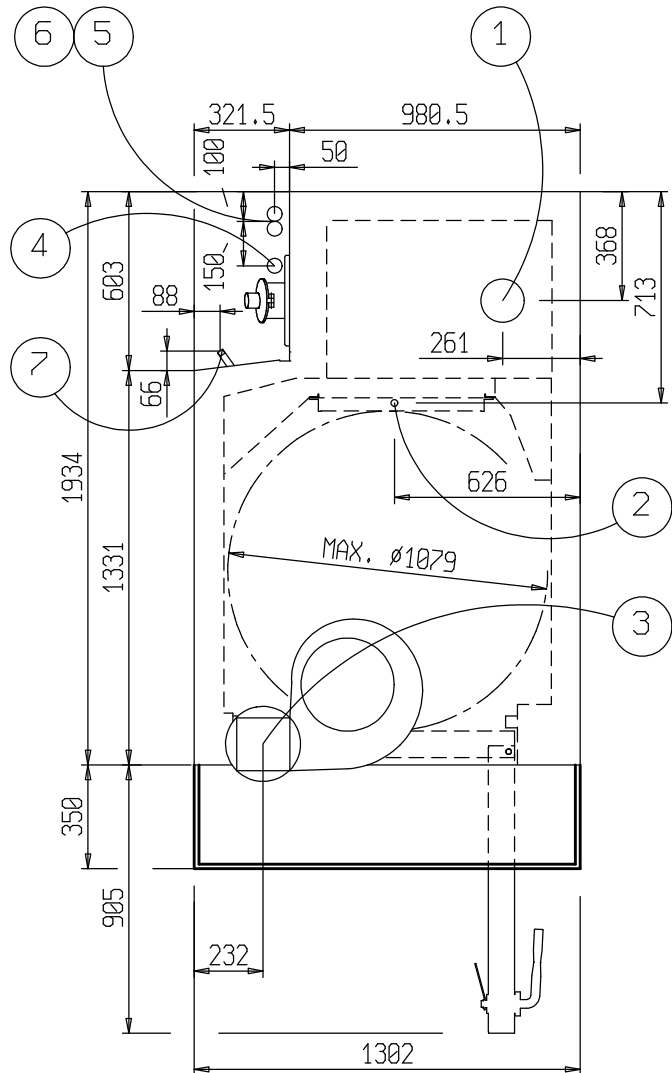

  
**DEKEGHEL**  
 Dekeghel nv  
 Overnelleweg 29  
 B-1740 Ternat  
 Tel +32(0)24606022  
 Fax +32(0)26692222  
 www.dekeghel.be info@dekeghel.be

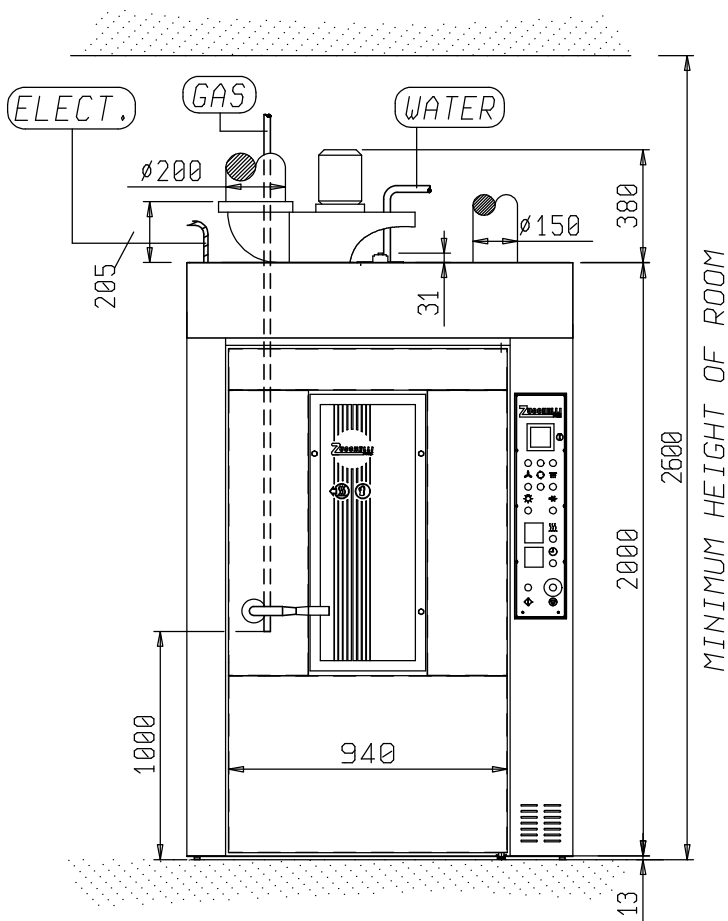

TURNTABLE - HOOR

8		
8		
7	WATER DISCHARGE	Ø 1/2"
6	BURNER SUPPLY OIL	Ø 3/8"
5	BURNER SUPPLY GAS	Ø 1 1/2"
4	ELECTRIC ENERGY ARRIVAL	KW 2
3	STEAM EXHAUST PIPE	Ø200
2	STEAM GENERATOR WATER ARRIVAL	Ø 1/2"
P	SMOKE EXHAUST PIPE	Ø150
<b>POS.</b>	<b>DENOMINATION</b>	

WEIGHT Kg. 1050  
 NOZZLE OIL GPH 1,5 A 60°  
 NEEDED KCAL OVEN KCAL 55.000

**TECHNICAL FEACTURES**  
**ROTORFAN 5 60x80 FN53**

BOLL. 931      DATA 22.11.00      VISTO .

DIS.       DIS. N° POS.311-1



DISEGNO DI PROPRIETA' RISERVATA E NON PUO' ESSERE RIPRODOTTO O MOSTRATO A TERZI AI SENSI DI LEGGE

MINIMUM PASSAGE FOR DISSEMBLED OVEN 760x1300